

OWNER'S MANUAL

MODEL *Three Thirty*

By

harman

kardon

Nocturne®

INTRODUCTION

Congratulations. You have just purchased one of the finest stereophonic music centers available. Your receiver represents the successful culmination of many years of intensive research in solid-state technology — a product literally born of space-age development. Before you lies the magnificent sound of recorded music as you have never heard it before.

We know how anxious you are to install and listen to your new receiver. However, a few moments spent in reading this instruction booklet will pay vast dividends in the ultimate enjoyment of your music system.

Please retain this booklet for it contains valuable information.

WARRANTY and SERVICE POLICY

POLICY

We warrant each unit to be free from defects in material and workmanship under normal use and service, and in accordance with the conditions set forth below. Should a defect occur within the period specified, and provided that the unit is returned to either HARMAN-KARDON or an authorized HARMAN-KARDON warranty station, transportation prepaid, and which our examination shall disclose to our satisfaction to be defective, we will:

- a) For a period of two (2) years from date of purchase either replace or repair and install any defective parts of the stereo receiver free of charge.

EXCEPTIONS

This warranty does not include any obligation as to:

- a) repair or replacement of the accessory wooden enclosure due to damage incurred after initial delivery.
- b) transportation charges to and from the factory or an authorized warranty station.

REGISTRATION

To obtain service under the terms of this policy, it is necessary to return the enclosed warranty card for "factory validation" within ten (10) days from the date of purchase.

This card will be assigned a "warranty registration number" and returned to you. If service is required within the warranty period, it is mandatory that the validated card or the warranty registration number be presented or your warranty will not be honored.

This warranty is not applicable to any instrument which shall have been repaired or altered in any way so as, in our judgment, to affect its stability or reliability or has been subject to neglect, misuse, abuse, negligence, or accident; or which has had the serial number altered, effaced or removed. Neither shall this warranty apply to any instrument which has been connected other than in accordance with instructions furnished by us.

SERVICE

HARMAN-KARDON has a special customer service division to answer all questions pertinent to the installation and operation of your unit. Please feel free to write to us at any time and we shall endeavor to offer prompt and complete advice.

If your problem cannot be resolved through our combined efforts, we may wish to refer you to a local authorized repair agency or we may prefer to authorize the return of your unit to the factory. In the event it must be returned, on authorization from and proper packing instructions will be forwarded to you. This authorization form, together with the warranty registration number, **MUST BE RETURNED** with your unit.

UNDER NO CIRCUMSTANCES SHOULD YOUR UNIT BE SHIPPED TO THE FACTORY WITHOUT PRIOR AUTHORIZATION.

This warranty is in lieu of all other warranties, expressed or implied, and of all other obligations or liabilities on our part, and we neither assume nor authorize any representative or other person to assume for us any other liability in connection with the sale of this instrument.

Harman-Kardon has established a special consumer division to answer all questions pertinent to the installation and operation of your unit. Please feel free to write us at any time and we will endeavor to offer prompt and complete advice.

If your problem cannot be resolved through our combined efforts we may wish to refer you to one of our authorized warranty stations. The unit must be shipped via Railway Express, Prepaid to the station designated, accompanied by a brief note describing the exact nature of the difficulty. **Under no circumstances should the set be shipped directly to the factory without prior authorization!**

INSTALLATION PROCEDURE

VENTILATION

Although your new Nocturne Receiver rarely develops high heat, it is still recommended that you leave the back of the cabinet open. If this is not possible, provide several large holes or slots as low down and as high up in the cabinet back as possible. As an alternate, holes may be provided in the sides, bottom or top of the cabinet. Remember that really effective ventilation requires provision for cool air to enter at the bottom and hot air to leave at the top. A minimum clearance of two (2) inches should be allowed on each side and in the rear, between the chassis and the cabinet, and three (3) inches are required above it.

Isolate any accessories which might interfere with ventilation. For example, do not drape plastic or rubber covered interconnecting cable over the equipment.

The rear panel surface of your receiver has been designed as a heat dissipating device for the output transistors. This area will become warm under normal use and should not be cause for concern.

Connect the AC line cord into any outlet furnishing 117 volts, 60 cycle AC current. The voltage may vary between 105 and 125 volts. An auxiliary AC power outlet is provided on the rear panel of your receiver. Any accessory equipment (tape recorder, phonograph record player, etc.) may be connected to this receptacle and will be controlled by the POWER switch on the front panel of your receiver.

CONNECTING THE SPEAKERS FOR STEREO OPERATION (1 SYSTEM)

Your two speakers should be identical, if possible, to obtain optimum results. Experts agree that a perfectly matched system offers the best stereophonic reproduction. The speakers should be placed along the same wall approximately 8 to 10 feet apart depending upon room size and furniture placement. It may be necessary to experiment with speaker placement until best results are obtained.

Use any type of wire to connect your speakers to your receiver. Lamp cord "zip cord" is excellent and may be easily dressed around the molding for an inconspicuous and neat installation. Do not drive the staples or tacks through the center of the wire for this may short out the two sections and will decrease the overall volume or short out the speakers entirely. It is permissible to use approximately 50 feet of speaker connecting wire for each speaker without loss of volume. **CONNECT SPEAKERS WITH CARE. AVOID SHORTS — RECEIVER HAS BEEN DESIGNED TO PREVENT DAMAGE FROM ACCIDENTAL SHORTING; HOWEVER, REPETITIVE SHORTING CAN DAMAGE TRANSISTORS.**

1. Connect one length of lamp cord to the left speaker. (This is the speaker on your left as you face the speakers. This speaker will now be referred to as Channel A.)

2. Attach the other end of the lamp cord to the terminals marked **SYSTEM 1 LEFT** located on the rear of the receiver.

3. Similarly connect another length of lamp cord to your right speaker. (This speaker will now be referred to as Channel B.)

4. Attach the other end of the lamp cord to the terminals marked **SYSTEM 1 RIGHT**.

5. Your receiver is now connected for 1 system stereo operation and is operative when the speaker switch on the front panel is in the **System 1 ON** position.

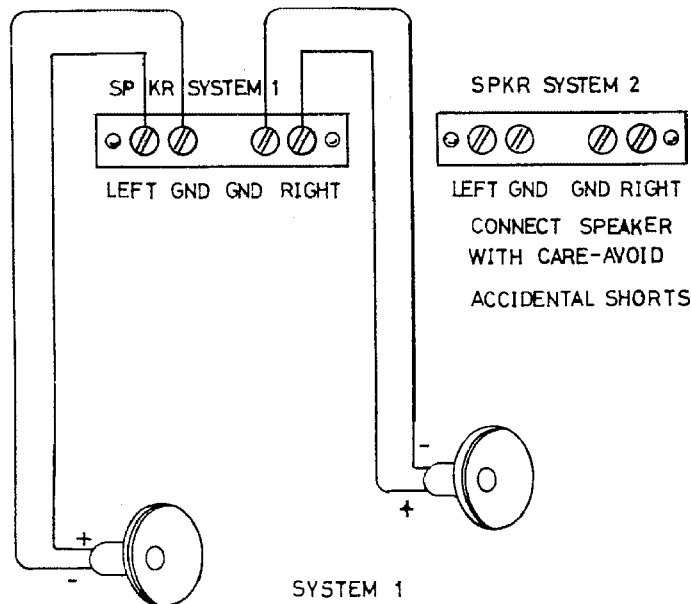

D I A G R A M A

SPEAKER PHASING

When more than one speaker is used in any music reproducing system the speakers must be connected in a manner to work together rather than work out of phase. If one speaker is pushing air out while the other is moving in the opposite direction this will result in diminishing bass response. Checking for proper phase and correcting if necessary is quite simple.

1. Place a stereophonic recording on your record player.

2. Place the Function switch in the **Phono** position.
3. Place the **Stereo/Mono** switch in the **Mono** position.
4. Play the record. The sound should emerge from approximately the center area between the two speakers.
5. While the record is playing place the **Stereo/Mono** switch in the **Stereo** position.

6. The sound should now move across the wall of the room and should appear to come from both speakers as well as the center.

7. If your speakers are out of phase, the sound source will not pinpoint itself between the two speakers when the **Stereo/Mono** switch is in the **Mono** position. Instead it will appear to come from both sides.

If the speakers are out of phase, turn off the receiver and disconnect both leads from either the left or right speaker and reverse them. Your system will now be in phase.

This completes your speaker connections. Your receiver is a solid state device which does not contain audio output transformers. It is therefore not necessary to match the impedance of your speakers to the receiver. Your unit will perform perfectly with any speaker which has an impedance of 4, 8 or 16 ohms.

SPEAKER SYSTEM SELECTOR SWITCHES

Your receiver has been provided with 2 independent speaker selector switches.

If your receiver is connected with 1 set of speakers (1 system) as described in previous paragraph on speaker connections, the system 1 speaker selector switch must be in the "on" position. If you have 2 sets of speakers (2 systems) the system 1 and system 2 speaker selector switches must both be in the "on" position for both systems to operate.

Should you desire to listen to stereo-headphone alone, the speakers (either one or both systems can be turned off at your discretion.)

STEREO HEADPHONE RECEPTACLE

The stereo headphone receptacle located on the front panel will accept any headphone with any impedance rating. The headphone receptacle is "on" at all times. If you wish to listen to the headphones alone, see the paragraph "Speaker Selector Switches".

CONNECTING THE SPEAKERS FOR STEREO OPERATION (2 SYSTEMS)

1. Connect all 4 speakers for your two system operation as shown in Diagram B.

2. You may now select either system 1, system 1 and 2, or system 2 by the use of the speaker selector switches located on the left side of the front panel of your Nocturne receiver.

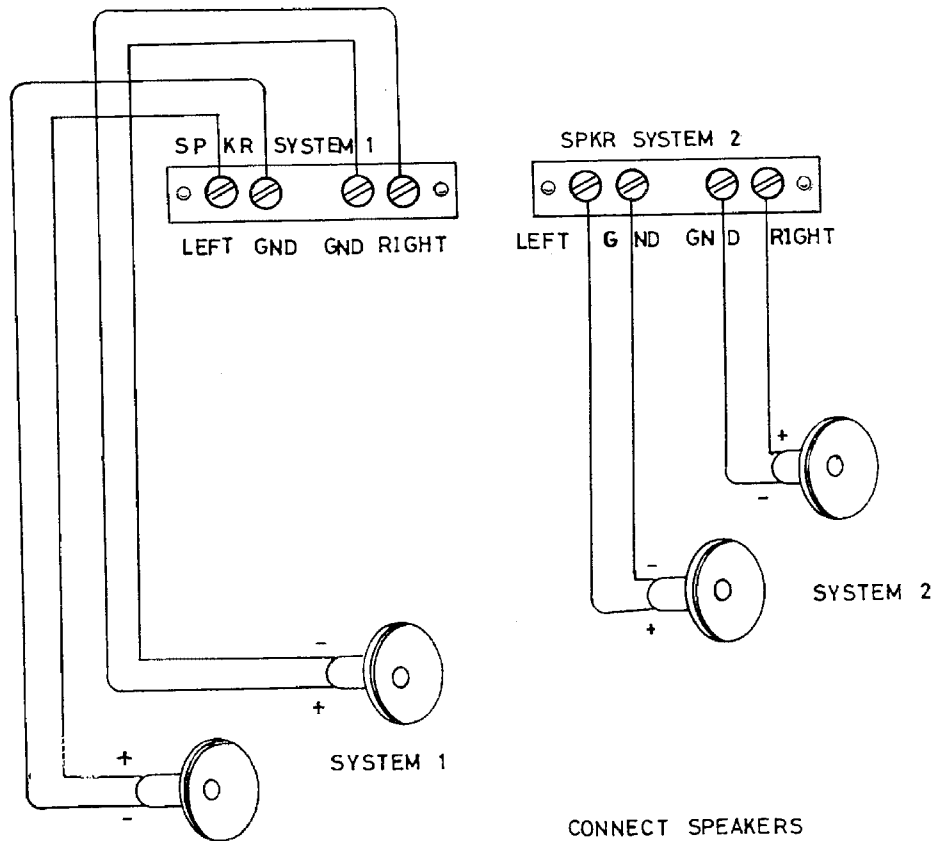

DIAGRAM B

CONNECT SPEAKERS
WITH CARE - AVOID
ACCIDENTAL SHORTS

CONNECTING THE SPEAKERS FOR MONOPHONIC OPERATION (1 SYSTEM)

If your receiver is to be used monophonically and stereo is to be added at a later date, it is essential that both speaker output terminals are terminated into a proper load to prevent damage to the output stage of the receiver. Refer to Diagram C for proper installation of the loading resistor.

At no time should the output terminals be paralleled for monophonic operation!

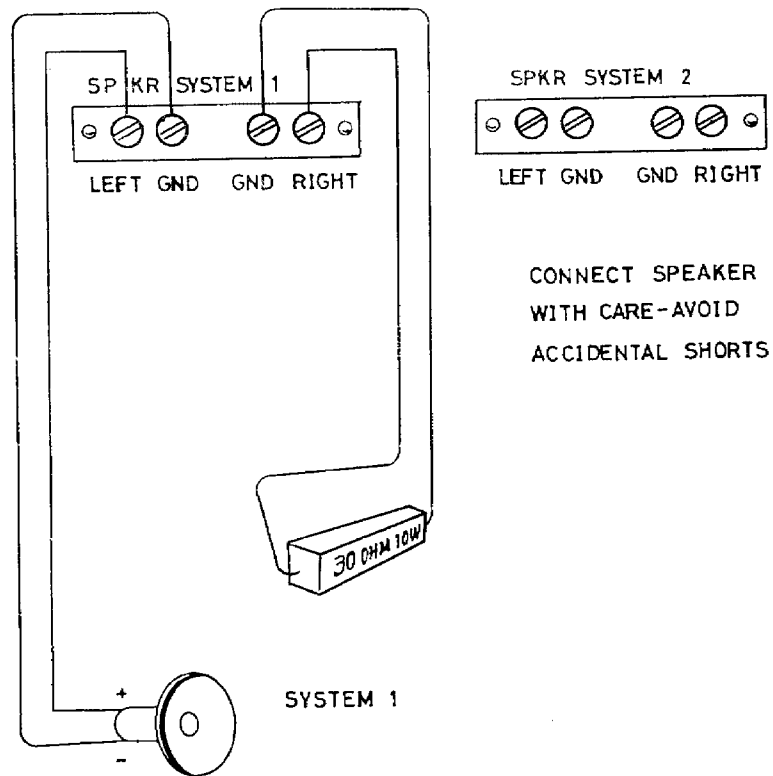

DIAGRAM C

THIS IS THE ONLY CORRECT METHOD FOR
CONNECTING ONE SPEAKER TO YOUR RECEIVER

CONNECTING THE SPEAKERS FOR MONOPHONIC OPERATION (2 SYSTEMS)

If your receiver is to be used monophonically and stereo is to be added at a later date, it is essential that both speaker output terminals are terminated into a proper load to prevent damage to the output stage of the receiver. Refer to Diagram D for proper installation of the loading resistors.

At no time should the output terminals be paralleled for monophonic operation!

CONNECTING THE SPEAKER FOR STEREOPHONIC OPERATION (SYSTEM 1) AND MONOPHONIC OPERATION (SYSTEM 2)

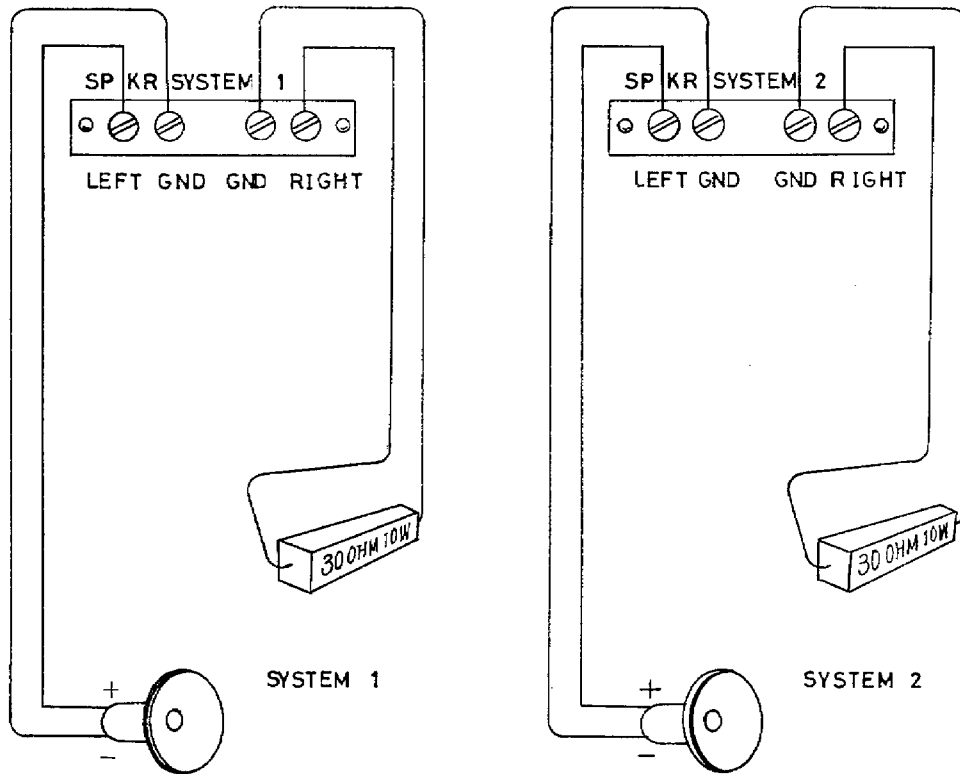

D I A G R A M D

CONNECT SPEAKERS
WITH CARE-AVOID
ACCIDENTAL SHORTS

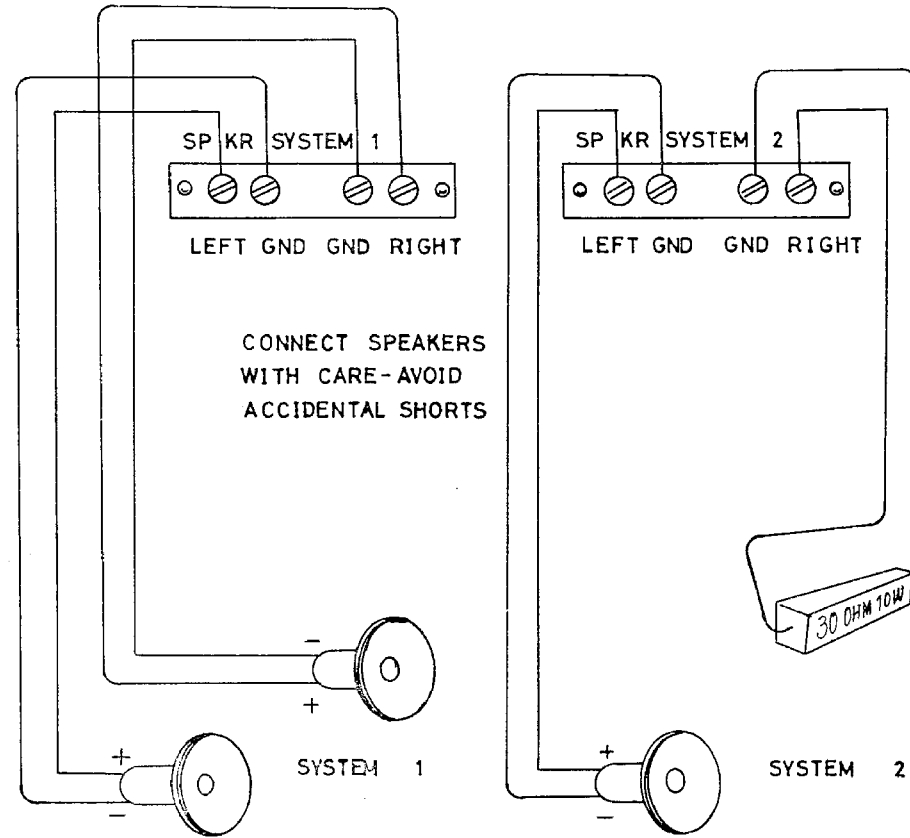

D I A G R A M E

CONNECTING THE FM ANTENNA

Due to the exceptionally high sensitivity of your receiver, the 48" wire supplied is sufficient for all but the most difficult locations. The balanced antenna input is designed to accept a 300 Ω antenna, indoor or outdoor type. When using the antenna supplied connect one end of the 48" wire to either of the FM antenna terminals. Horizontal placement of the antenna will yield optimum reception. The antenna may be tacked to the back of the molding behind the equipment or to the shelf you use.

As FM signals are in the same broadcast frequency range as TV signals, they are affected by the same external conditions. Just as TV reception is improved, you can improve your FM reception with an external antenna. When using an external antenna, connect both leads of the antenna wire to the two FM antenna terminal posts on the rear of your receiver.

CONNECTING THE AM ANTENNA

The AM loopstick fastened on the rear of your receiver comprises all the antenna usually required for normal signal areas. In more remote locations an additional outdoor antenna may be required. This should consist of a single wire, as long as is reasonably practical. It must be kept away from large metal objects, power lines or electrical machinery to insure reception without extraneous noise. Attach this length of wire to the AM terminal of the ANTENNA TERMINAL STRIP.

CONNECTING A STEREO RECORD PLAYER (MAGNETIC PICKUP)

Connect both leads from your record player to the LEFT and RIGHT PHONO MAG input receptacles on the rear of the receiver chassis. If your record player has a special ground wire emerging with the two input leads, connect this ground wire to the ground terminal on the rear of the receiver.

CONNECTING A MONOPHONIC RECORD PLAYER (MAGNETIC PICKUP)

Connect the single lead from your monophonic record player to either the LEFT or RIGHT PHONO MAG input receptacles on the rear of the receiver chassis.

CONNECTING A STEREO TAPE RECORDER

Connect the two tape recorder output cables to the LEFT and RIGHT TAPE AMP/AUX input receptacles on the rear of your receiver. With the Function Switch in the TAPE AMP/AUX position you will now be able to play your stereo tapes.

If your tape recorder has a special "monitor head", connect the two tape recorder output cables to the left and right TAPE-MON

receptacles on the rear of your receiver. This will now enable you to monitor your tapes as they are being recorded. Refer to paragraph "Source/Monitor Switch".

In order to make a recording, connect the inputs of your tape recorder to the TAPE OUT receptacles on the rear of the receiver. This will allow you to make a stereophonic recording while simultaneously listening to the program material through your speaker system.

CONNECTING A MONOPHONIC TAPE RECORDER

If a monophonic tape recorder is to be used with your receiver connect the recorder output to either the LEFT or RIGHT AUX input receptacle located on the rear panel. This will enable you to play back your monophonic tapes.

If your recorder is stereo playback but records monophonically, connect the output as described in the previous section on connecting a stereo tape recorder. Connect the input for recording monophonically as described below.

Connect the input of your recorder to either the LEFT or RIGHT TAPE OUT receptacle. This will enable you to record monophonically while simultaneously listening to the program through the receiver and speakers.

OPERATION PROCEDURE

Every control on this receiver serves a specific useful function and is important for the proper operation of your stereo system.

We recommend that you read the following section carefully so you may take full advantage of the performance capabilities of your receiver.

BALANCE CONTROL

The balance control is used to adjust the sound level of each channel with relation to each other.

The nature of stereophonic reproduction is such that it requires two identical channels to obtain the optimum stereo effect. As there may be slight differences between the location of the two speakers, tape heads, cartridges, etc., the balance control is provided to permit re-balancing of the overall system even in extreme cases where unbalance exists.

It should be noted that the Balance Control may be set anywhere within its range of adjustment to attain system balance.

VOLUME CONTROL

The Volume Control is used to adjust the volume level of any program material fed into the stereo system. The control varies both channels simultaneously therefore eliminating the necessity of balancing your system each time you change the volume level.

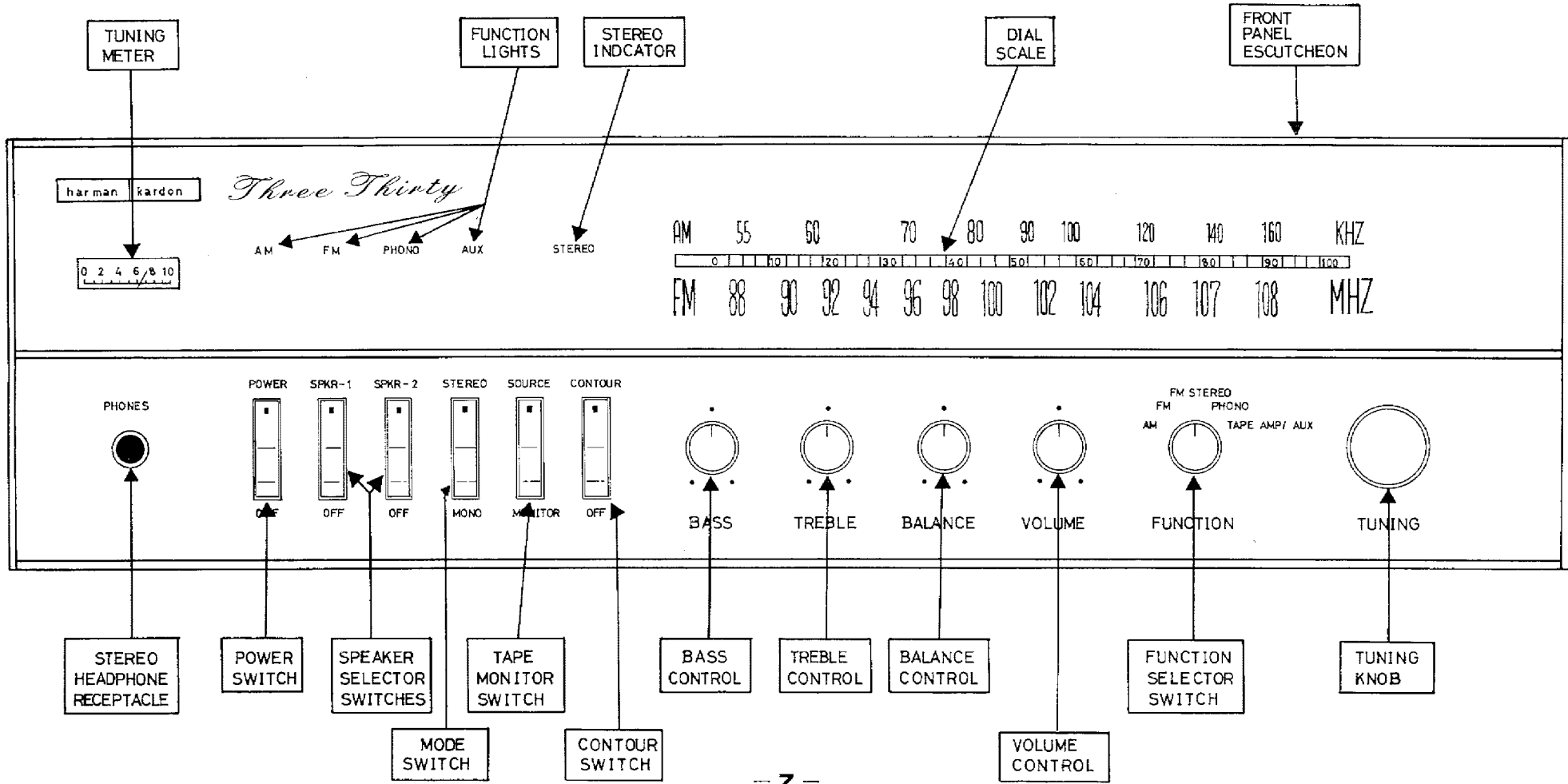

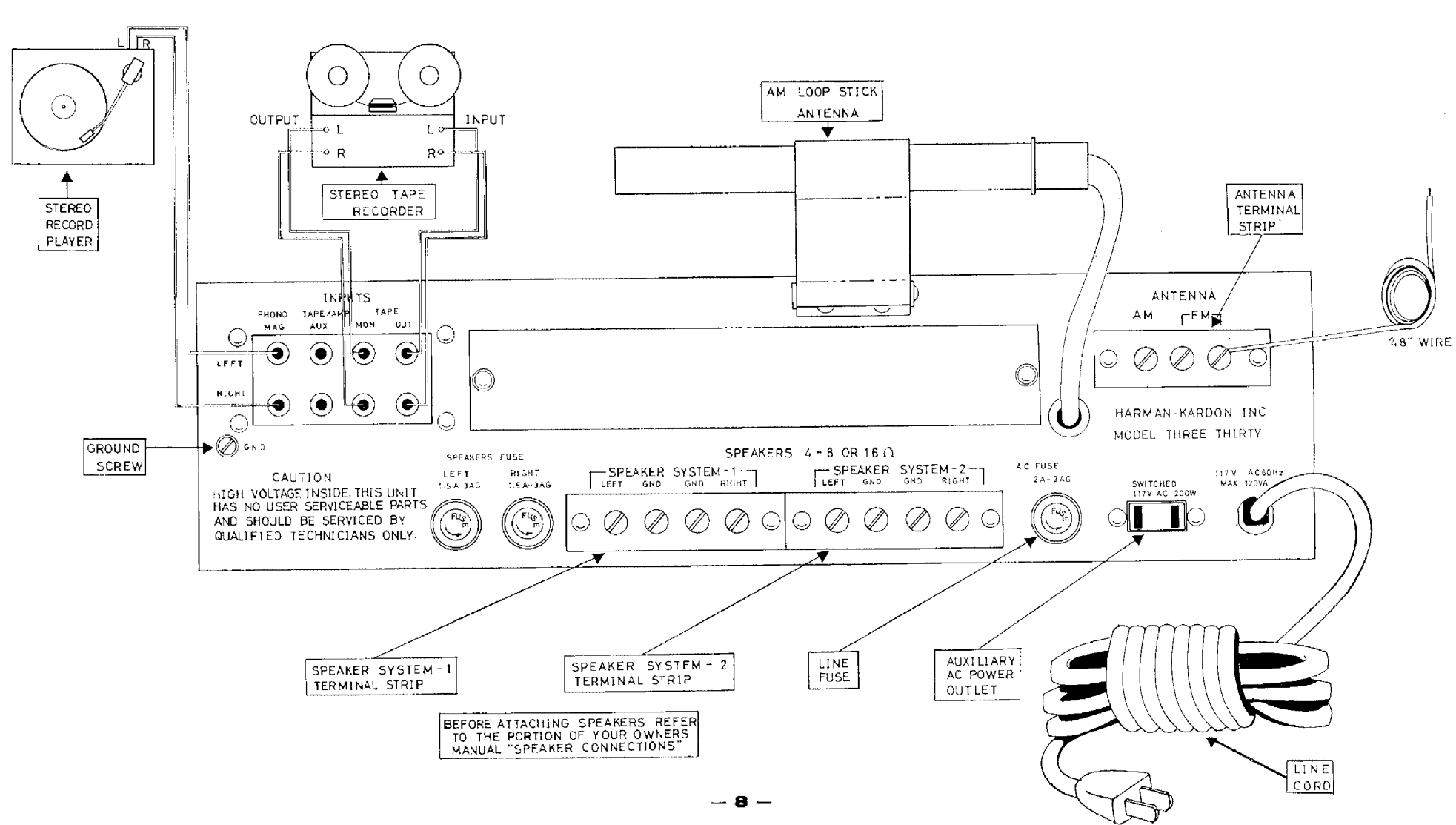

BASS AND TREBLE CONTROLS

The BASS and TREBLE tone controls on your receiver provide the full range of tonal adjustment necessary for stereo high fidelity listening. The tone control range is considerable and can adequately adjust the low and high frequencies in accordance with your listening preference, speaker characteristics and room acoustics.

FUNCTION SELECTOR SWITCH

The Function Selector Switch selects the desired type of program source to be heard through your system.

1. AM: This position selects the AM section of your receiver for AM reception.
2. FM: Selects the FM section of your receiver. In this position you can listen to stereophonic broadcasts monophonically while monophonic broadcasts will appear unchanged.
3. FM STEREO: This is the normal listening position for all monophonic or stereophonic FM broadcasts. In this position the stereo indicator light and automatic switching circuit built into your receiver are operative. For further details see the paragraphs on "Stereo Indicator Light" and "Selecting Monophonic or Stereo FM Broadcasts".
4. PHONO: Selects your record player for stereophonic operation.
5. TAPE AMP/AUX: Selects any program source such as tape recorder, the output of your television set, or any other high level equipment connected to the TAPE AMP/AUX receptacles on the rear of your receiver.

POWER ON/OFF SWITCH

Be sure to turn this switch OFF when not using the receiver.

SPEAKER SELECTOR SWITCHES

Refer to paragraph on speaker connections.

STEREO-MONO SWITCH

When the switch is in the "STEREO" position the receiver is operating stereophonically. When the switch is in the "MONO" position the receiver is operating monophonically. This position may be used when listening to monophonic records, or when it is desired to reproduce a stereo program, such as an FM stereo broadcast, monophonically.

SOURCE/MONITOR SWITCH

If your tape recorder has a special monitoring feature, throwing

the tape monitor switch to the "mon" position will enable you to listen to your tapes a second after they are recorded. When not in use, this switch must be in the "source" position. If your tape recorder does not have any monitoring feature, throwing this switch will result in zero output from your speaker system.

CONTOUR SWITCH

One of the limitations of human hearing is its tendency to lose sensitivity to the very low pitched sounds as the program sound level is reduced. It is this characteristic (known as the Fletcher-Munson effect) which causes one to play music programs at high listening levels in order to experience the full rich tone available from fine modern recordings.

The Harman-Kardon CONTOUR switch compensates for this effect; thereby eliminating high listening levels as a requisite for full enjoyment of reproduced music. For warm, full-bodied reproduction at low listening levels, throw the CONTOUR switch "IN". At high levels, the CONTOUR switch has no effect.

SELECTING MONOPHONIC OR FM STEREO BROADCASTS

Under normal use for all FM broadcasts the function Selector switch should be placed in the FM STEREO position.

Your receiver is equipped with a stereo sensing circuit which can automatically determine if your unit is receiving monophonic or stereophonic broadcasts, and then automatically adjust the mode of operation.

If the station is transmitting stereo, your receiver will automatically switch in the multiplex section and you will hear the broadcast in full stereo. Should the station conclude broadcasting in stereo, your receiver will automatically switch back to monophonic reception.

Should you receive a weak stereo signal whose quality has been degraded by noise or poor signal conditions, and you wish to listen to this stereo broadcast, monophonically, place the function selector switch in the FM position.

DIAL SCALE

The Dial Scale on your THREE-THIRTY receiver is marked with three (3) scales, an FM frequency scale (88-108 MHz), a logging scale (0-100), and an AM frequency scale.

Since most FM stations operate on frequencies which are not whole numbers (such as 96 MHz as compared to 96.3) ideally each megacycle division on the frequency scale should be divided into 10 parts to enable the user to pinpoint the location of the station. This would require a dial scale which would be longer than the front panel.

The logging scale which is divided into 100 equal parts provides a means of finding your favorite station, once you have noted its position on the logging scale. For example, in New York City, WQXR operates on 96.3 MHz. After locating this station through the use of the frequency scale (between 96 and 98 MHz), you find that the pointer may fall on 35 on the logging scale. Make a note of this setting. For future tuning to WQXR simply set the pointer to 35 on the logging scale.

STEREO INDICATOR

A stereo indicator is located directly behind the dial glass and operates in conjunction with the FM STEREO position of the Function Selector switch. The indicator visually shows the reproduction of FM stereo through your receiver.

To tune for FM stereo proceed as follows:

1. Place the function selector switch in the FM STEREO position.
2. Tune to the station of your choice using your tuning meter for precise and accurate tuning. Your stereo indicator will now show if you are tuned to a stereo program. If the indicator is OFF, the program you are listening to is being broadcast monophonically.

TUNING METER

Your receiver incorporates a D'Arsonval movement tuning meter for precise tuning of your receiver.

Proper tuning is indicated by maximum deflection (higher number) of the needle. Stronger stations show greater needle movement.

TUNING

The tuning knob, located directly at the right of the receiver is used to select the desired station when your selector switch is in the FM, FM stereo, or AM position.

FUNCTION INDICATOR LIGHTS

The function indicator lights are located behind the dial glass and visually indicate the position of the function switch.

EQUALIZATION

In order to achieve good reproduction of the wide range of frequencies in music and to make necessary adjustment for the limitations of the recording technique, record manufacturers have found it necessary to modify the actual frequency response of the

music while it is being recorded. Thus, to avoid overcutting and consequent distortion, a measured and deliberate reduction is effected in low frequency response by selecting a "turnover frequency" and by recording attenuated response below that point. To assure optimum signal to noise at the high frequency end when the record is played at home, the highs are deliberately exaggerated during the recording process. A measured and deliberate boost is affected above a certain frequency. This combination of deliberate exaggeration at the low and high ends of the frequency response can be expressed in a recording curve. When the record is played a mirror image of that curve should be available so that the ideal "flat" response may be achieved.

The PHONO position of the Function Selector automatically selects the proper equalization that is required.

HUM AND NOISE

In any high fidelity installation, hum may be caused by the interconnection of a record player, tuner and amplifier, as a result of the cables and different grounds. If hum is experienced with your receiver, disconnect everything but the speakers from the receiver. If hum persists, reverse the AC line cord. Plug in the record player and if hum appears, reverse the record player power plug and connect a single lead from the record player chassis to the ground post on the rear of the receiver chassis. Connect your other devices in this manner. CAUTION: Hum may be also induced by defective connecting cables or by running these cables too close to a strong AC field.

SERVICE

If this instrument should not perform properly during the first two (2) years after date of purchase, contact the factory for instructions. The factory has many authorized warranty service stations in the United States. To aid us in selecting a service station convenient to you, it would be helpful if you would indicate what major city is closest to your home. Please write our Customer Service Department, Harman-Kardon, Incorporated, Plainview, New York 11803. Be sure to include the model and serial number of the unit. A brief description of your other components is often of help in answering your questions. DO NOT return this instrument to Harman-Kardon without first receiving authorization.

CUSTOM INSTALLATION

1. Locate and drill (4) $\frac{1}{4}$ " diameter holes on mounting shelf.
2. Position and cut out front panel opening. (Bottom of opening should be flush with top of mounting shelf.)
3. Remove (4) rubber feet from unit. (Rubber feet and screws are no longer used for cabinet installation).
4. Remove (2) screws & washers from top of metal enclosure.
5. Install unit from front through panel cutout opening.
6. Fasten unit to mounting shelf. If $\frac{1}{2}$ " thick mounting shelf was used fasten with (4) No. 6 \times $\frac{3}{4}$ " long self-tapping screws and washers. If $\frac{3}{4}$ " shelf was used fasten with (4) No. 6 \times 1" long self-tapping screws and washers.

